

SAIL No. _____

SAIL MEASUREMENT FORM

STANDARD CLASS RULES FOR SAIL MEASUREMENT

Based on World Sailing’s “Equipment Rules of Sailing 2017-2020”

- 1. **GENERAL**
- 1.1. Anything not specifically permitted by these rules is **PROHIBITED**.
- 1.2. Sails shall be made and measured in accordance with the World Sailing’s “Equipment Rules of Sailing 2017-2020” except where varied herein. Where terms are defined or measurements given and the World Sailing’s ERS are used it is printed in **CAPITALS UNDERLINED**.
- 1.3. The Manufacturer of **SAILS** is optional.
- 2. **MAINSAIL**
- 2.1 **CONSTRUCTION**
- 2.1.1 Construction shall be: **SOFT SAIL, SINGLE PLY SAIL.**
- 2.1.2 The ply fibres of the body of the sail to be made of white Polyester cloth, or alternatively from a laminate material reinforced with a polyester weave. The sail shall be edged in red tape.
- 3. The SAIL shall have **3 BATTEN POCKETS** in the **LEECH**.
- 4. The following are permitted: **STITCHING, GLUES, BOLT ROPES, CORNER EYES, HEADBOARD WITH FIXINGS, CUNNINGHAM EYE, BATTEN POCKET ELASTIC, SAILMAKERS LABEL, TELL TAILS.**
The corner eye on the luff is to be the Cunningham Eye. 2 eyes are not permitted.

2.2 **DIMENSIONS** **MAXIMUM**

ACTUAL	MAXIMUM	
<u>LEECH LENGTH</u>	5235mm	
Foot median	4970mm	
<u>QUARTER WIDTH</u>	2145mm	
<u>HALF WIDTH</u>	1595mm	
<u>THREE QUARTER WIDTH</u>	890mm	
<u>TOP WIDTH</u>	118mm	
<u>PRIMARY REINFORCEMENT</u>	300mm	
<u>SECONDARY REINFORCEMENT:</u>		
From <u>CORNER MEASUREMENT POINTS</u>	900mm	
<u>TABLING WIDTH</u>	40mm	
<u>SEAM WIDTH</u>	15mm	
Maximum dimension of headboard on mainsail	148mm	
<u>BATTEN POCKET LENGTH:</u> (all pockets)		
<u>OUTSIDE:</u>	635mm	
<u>INSIDE:</u>	620mm	
<u>BATTEN POCKET WIDTH:</u>		
<u>OUTSIDE:</u>	80mm	
<u>INSIDE:</u>	50mm	
<u>DIAMETER OF BATTEN POCKET INNER END</u>		
<u>REINFORCING PATCHES.</u>	160mm	
Check the centreline of the 3 batten pockets are within 50mm Of the ¼, ½, & ¾ height points on the leach		

WINDOW AREA:

one shall not exceed a rectangle 2500mm in width x 300mm in height
second shall not exceed 300mm in length and 400 mm in height

3. **FORE SAIL**

1. **CONSTRUCTION**

1.1. Construction shall be: **SOFT SAIL, SINGLE PLY SAIL**

1.2. The **BODY OF THE SAIL** shall consist of the same **WOVEN PLY** throughout. The **PLY** fibres shall be of polyester. The sail shall be white with red tabling. The tabling can be omitted from the leech only where it is hot cut.

1.3. The following are permitted: **STITCHING, GLUES, CORNER EYES, ONE WINDOW, SAILMAKERS LABEL, TELL TAILS, CHAFFING PATCH, JIB HANKS.** Permanent attachment of the fore sail luff to the eye in the luff wire at the head of the sail is optional, but must not be permanently secured to the eye in the luff wire at the tack

1.4.

3.2

DIMENSIONS

LUFF LENGTH

LEECH LENGTH

FOOT LENGTH

FOOT MEDIAN

TOP WIDTH

PRIMARY REINFORCEMENT

SECONDARY REINFORCEMENT:

From **CORNER MEASUREMENT POINTS**

TABLING WIDTH

SEAM WIDTH

WINDOW AREA:

shall not exceed a rectangle width 1300mm x 300mm ht.

MAXIMUM

MIN

3505mm

3130mm

1340mm

3335mm

45mm

250mm

750mm

40mm

15mm

2. **SPINNAKER** (measured folded in half – leech to leech)

2.1. **CONSTRUCTION**

2.1.1. Construction shall be: **SOFT SAIL, SINGLE PLY SAIL**

Shall be symmetrical in form and construction.

No more than five seams stretching from leech to leech and one central seam if required.

Radial and tri-radial spinnakers are not allowed.

Headboards are not permitted.

Sail numbers are not required.

2.1.2. The following are permitted: **STITCHING, GLUES, TAPES, CORNER EYES, RECOVERY LINE EYES** (up to two), **SAILMAKERS LABEL, TELL TAILS.**

4.2 **DIMENSIONS (to be measured as a spinnaker)**

MAXIMUM

MINIMUM

LEECH LENGTHS

FOOT LENGTH

FOOT MEDIAN

Half height cross measurement

Spinnaker clew to half height centre seam

PRIMARY REINFORCEMENT

3650mm

2500mm

3935mm

1230mm

2150mm

250mm

1140

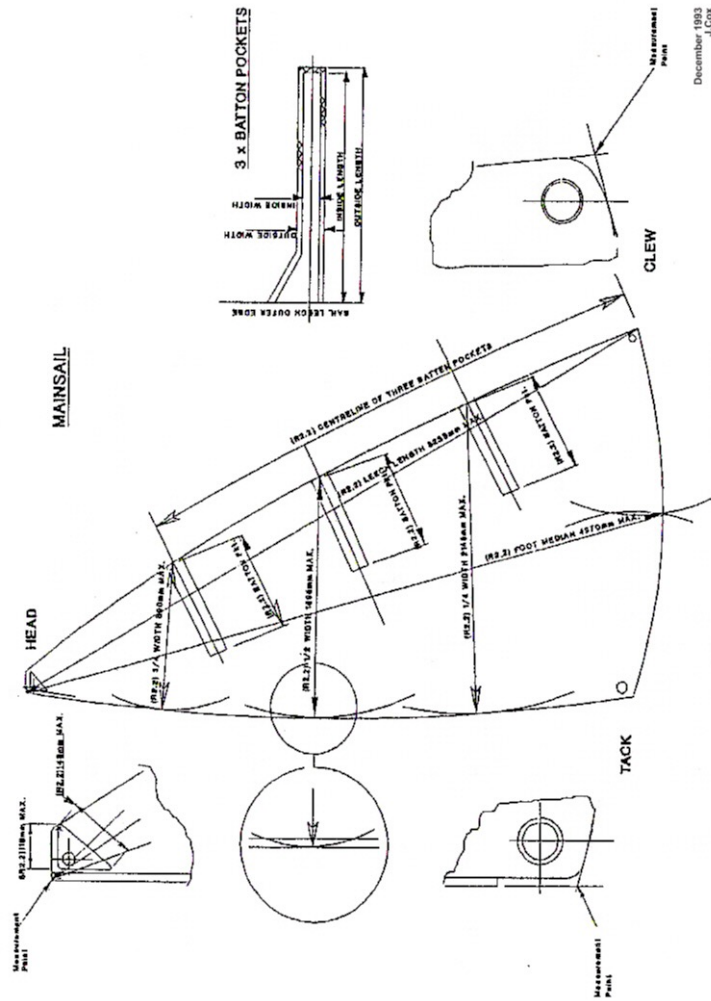

HEADSAIL

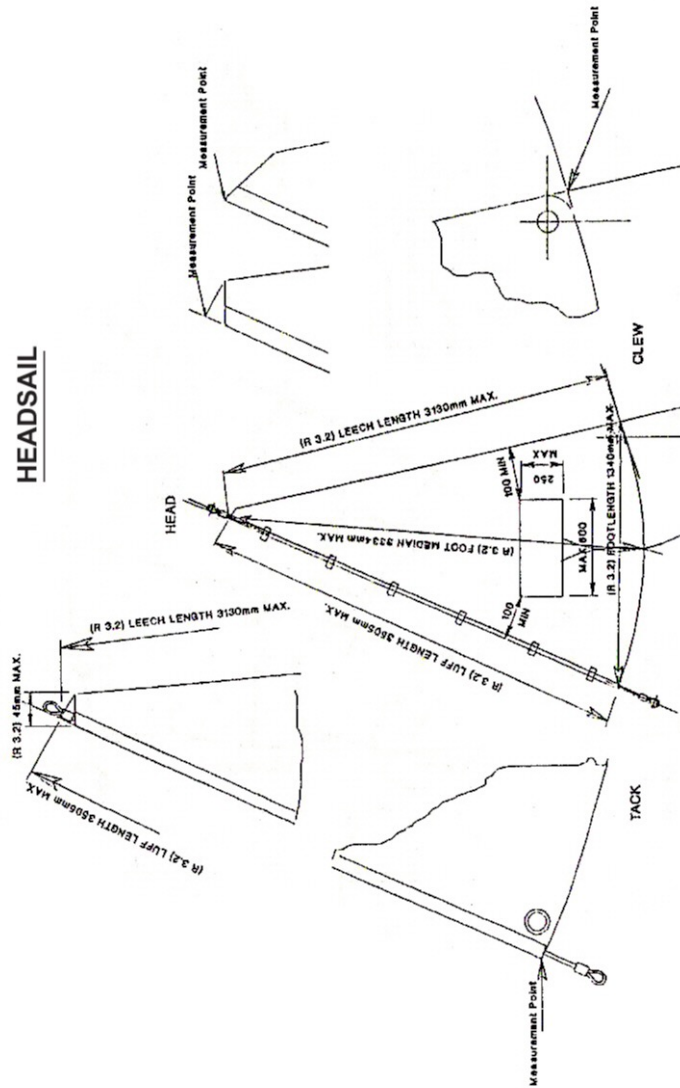

December 1993
J.Cox

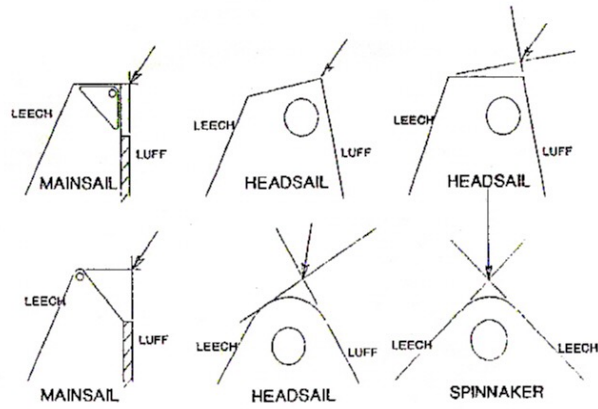
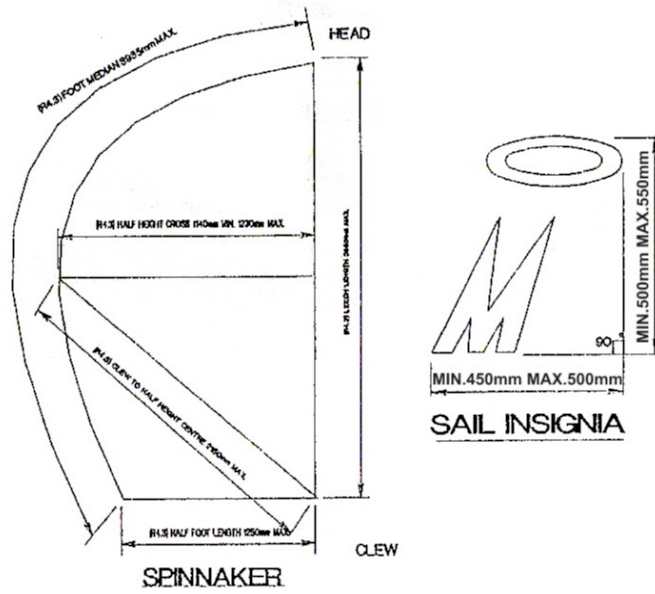

Head measurement point

July 1993
J.Cox